

Features:

- Excitation system: self-excited (AREP and PMG are optional)
- ATS (automatic transfer switch) receptacle
- Lockable battery isolator switch
- Stainless galvanized zinc plates with strong corrosion resistance
- Vibration isolators between the engine/alternator and base frame
- Integrated wiring design
- Base fuel tank for at least 8 hours running
- Equipped with an industrial muffler
- Engine oil pump
- 50 C radiator
- Top lifting and steel base frame with forklift holes
- Drainage for fuel tank
- Complete protection functions and safety labels
- IP44 (soundproof sets), IP54 (control system)
- Water jacket preheater, oil heater and double air cleaner, etc. are available.



Output Ratings

Generating Set Model	Prime	Standby
WCS550/S	500kVA/400kW	550kVA/440kW

Ratings at 0.8 power factor.

Ratings and Performance Data

Engine Make & Model:	QSX15-G8	
Alternator Model:	HCI544D	
Alternator Brand:	STAMFORD	
Control System:	PLC-920 / PLC-7420	
Noise Level@7m:	73-83	
Frequency & Phase:	50Hz & 3PH	
Engine Speed: RPM	1500	
Structure Type:	WCS550	A
	WCS550S	R
Fuel Tank Capacity: L	WCS550	940
	WCS550S	950
Fuel Consumption: l/h	at 100% load	97.9
	at 75% load	74.8

Dimensions and Weights

Generating Set Model	Length (L) mm (in)	Width (W) mm (in)	Height (H) mm (in)	Dry kg (lb)
WCS550	3485	1340	2020	4245
WCS550S	4500	1550	2450	5710

Dry = With Lube Oil Wet = With Lube Oil and Coolant

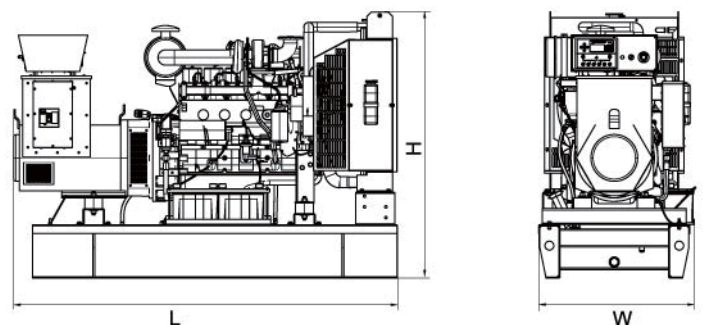
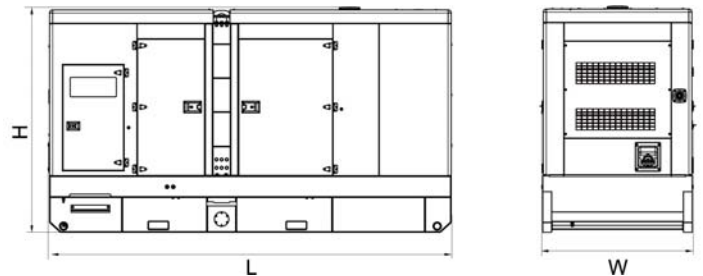

Also available in the following voltages: 415/240V-380/220V-220/127V-200/115V;

ESP: Standby Power Standby duty, operation under variable load, without over load;

PRP: Prime Power-Continuous duty operation, under variable load 24/24h-10% over load permissible 1 hour/12 hours;

The data is only for your reference but not for use of sales.

M: Mechanical speed governor, E/EUCU: Electronic speed governor;

NA: Naturally aspirated, TC: Turbocharged, TCA: Turbocharged and air-air aftercooled, TCW: Water-cooled Turbocharged;

The weights are approximate and without fuel.

Engine model: QSX15-G8

GENERAL ENGINE DATA

Type	4 Cycle; In-line; 6-Cylinder Diesel	
Aspiration	Turbocharged and Charge Air Cooled	
Bore x Stroke	5.39 x 6.65 (137 x 169)	
Displacement	912 (15)	
Compression Ratio	17 : 1	
Dry Weight (Approximate), Fan to Flywheel Engine	— lb (kg)	3020 (1370)
Wet Weight (Approximate), Fan to Flywheel Engine	— lb (kg)	3250 (1475)
Moment of Inertia of Rotating Components		
• with FW 1022 Flywheel	— lb _m • ft ² (kg • m ²)	106.7 (4.5)
• with FW 1025 Flywheel	— lb _m • ft ² (kg • m ²)	192.0 (8.1)
Center of Gravity from Front Face of Block	— in (mm)	19 (483)
Center of Gravity above Crankshaft Centerline	— in (mm)	10 (255)
Maximum Static Loading at Rear Main Bearing	— lb (kg)	5400 (2450)

ENGINE MOUNTING

Maximum Bending Moment at Rear Face of Block	— lb • ft (N • m)	1500 (2034)
--	-------------------	-------------

EXHAUST SYSTEM

Maximum Back Pressure at Standby Power Rating	— in Hg (mm Hg)	3 (76)
Maximum Bending Moment to the Turbo Flange	— lb • ft (N • m)	11 (15)

AIR INDUCTION SYSTEM

Maximum Temperature Rise Between Engine Air Inlet and Intake Manifold	— °F (°C)	43 (24)
Maximum Intake Air Restriction Including Air Filter Plumbing		
• with Dirty Filter Element	— in H ₂ O (mm H ₂ O)	25 (635)
• with Clean Filter Element	— in H ₂ O (mm H ₂ O)	15 (381)
Maximum Allowable Pressure Drop from Turbo Outlet to Intake Manifold	— in Hg (mm Hg)	4 (102)

COOLING SYSTEM

Coolant Capacity — Engine Only	— US qt (liter)	25 (24)
Maximum Coolant Friction Head External to Engine — 1800 rpm	— psi (kPa)	10 (69)
— 1500 rpm	— psi (kPa)	8 (55)
Maximum Static Head of Coolant Above Engine Crank Centerline	— ft (m)	46 (14)
Standard Thermostat (Modulating) Range	— °F (°C)	180-200 (82 -93)
Minimum Pressure Cap	— psi (kPa)	10 (70)
Maximum Top Tank Temperature for Standby / Prime Power	— °F (°C)	23 /220 (110/104)

LUBRICATION SYSTEM

Oil Pressure @ Idle Speed (Minimum)	— psi (kPa)	20 (138)
@ Pressure Range — Cold	— psi (kPa)	Up to 130 (Up to 900)
— Warm	— psi (kPa)	35-40 (242-276)
Maximum Oil Temperature	— °F (°C)	250 (121)
Oil Capacity with OP 1493 Oil Pan : High - Low	— US gal (liter)	22-19 (83-72)
Total System Capacity (Including Filter)	— US gal (liter)	24 (91)

FUEL SYSTEM

Type Injection System	Cummins HPI-TP	
Maximum Restriction at OEM Inlet Connection	— in Hg (mm Hg)	5.0 (127)
Maximum Allowable Head on Injector Return Line (Consisting of Friction Head and Static Head)	— in Hg (mm Hg)	6.5 (165)
Maximum Fuel Flow to Injection Pump	— US gph (liter/hr)	112 (424)

Engine model: QSX15-G8

Maximum Fuel Inlet Temperature.....	— °F (°C)	160	(71)
Maximum Return Fuel Flow	— US gph (liter/hr)	102	(386)
Maximum Return Fuel Temperature @ 160°F (71°C) Fuel Inlet Temperature	— °F (°C)	210	(99)
Minimum Fuel Tank Vent Capability	— cfm (liter/s)	1.2	(.55)

ELECTRICAL SYSTEM

Cranking Motor (Heavy Duty, Positive Engagement).....	— volt	24
Maximum Allowable Resistance of Cranking Circuit	— ohm	0.002
Minimum Recommended Battery Capacity		
• Cold Soak @ 0 °F to 32 °F (-18 °C to 0 °C)	— 0°F CCA	1425

COLD START CAPABILITY

Minimum Ambient Temperature for Cold Start with Coolant Heater to Rated Speed	— °F (°C)	7	(-14)
Minimum Ambient Temperature for Unaided Cold Start to Low Idle Speed.....	— °F (°C)	25	(-4)
Minimum Ambient Temperature for NFPA 110 Cold Start (90°F minimum coolant temperature).....	— °F (°C)	32	(0)

PERFORMANCE DATA

- All data is based on:
- Engine operating with fuel system, water pump, lubricating oil pump, air cleaner and exhaust silencer; not included are battery charging alternator, fan, and optional driven components.
 - Engine operating with fuel corresponding to grade No. 2-D per ASTM D975.
 - ISO 3046, Part 1, Standard Reference Conditions of:

Barometric Pressure	: 100 kPa (29.53 in Hg)	Air Temperature	: 25 °C (77 °F)
Altitude	: 110 m (361 ft)	Relative Humidity	: 30%

Steady State Stability Band at any Constant Load	— %	+/- 0.25%
Estimated Free Field Sound Pressure Level of a Typical Generator Set;		
Excludes Exhaust Noise; at Rated Load and 7.5 m (25 ft); 1800 rpm / 1500 rpm	— dBA	89.0 / 89.5
Exhaust Noise at 1 m Horizontally from Centerline of Exhaust Pipe Outlet Upwards at 45°; 1800 rpm / 1500 rpm	— dBA	125 / 123

Governed Engine Speed.....	rpm
Engine Idle Speed.....	rpm
Gross Engine Power Output.....	hp (kW _m)
Brake Mean Effective Pressure.....	psi (kPa)
Piston Speed	ft/min (m/s)
Friction Horsepower.....	HP (kW _m)
Engine Water Flow at Stated Friction Head External to Engine:	
• 3 psi Friction Head.....	US gpm (liter/s)
• Maximum Friction Head	US gpm (liter/s)
Turbo Compressor Outlet Pressure.....	psi (kPa)
Turbo Compressor Outlet Temperature	°F (°C)
Intake Air Flow.....	cfm (liter/s)
Exhaust Gas Temperature.....	°F (°C)
Exhaust Gas Flow.....	cfm (liter/s)
Air-to-Fuel Ratio	air : fuel
Radiated Heat to Ambient	BTU/min (kW _m)
Heat Rejection to Coolant.....	BTU/min (kW _m)
Heat Rejection to Exhaust.....	BTU/min (kW _m)
Heat Rejection to Fuel *	BTU/min (kW _m)
Heat Rejection to Aftercooler.....	BTU/min (kW _m)

STANDBY POWER		PRIME POWER	
60 hz	50 hz	60 hz	50 hz
1800	1500	1800	1500
675 - 775	675 - 775	675 - 775	675 - 775
610 (455)	670 (500)	555 (414)	595 (444)
293 (2020)	388 (2675)	267 (1840)	344 (2371)
1995 (10.1)	1663 (8.4)	1995 (10.1)	1663 (8.4)
70 (52)	50 (37)	70 (52)	50 (37)
105 (6.6)	84 (5.3)	105 (6.6)	84 (5.3)
87 (5.5)	68 (4.3)	87 (5.5)	68 (4.3)
34 (236)	40 (272)	33 (228)	35 (246)
407 (208)	437 (225)	385 (196)	401 (205)
1290 (608)	1280 (605)	1260 (595)	1150 (540)
830 (443)	960 (515)	815 (435)	910 (488)
3200 (1510)	2900 (1370)	2905 (1370)	2660 (1255)
28.5 : 1	24.4 : 1	29.9 : 1	25.5 : 1
2050 (36)	2260 (40)	2090 (37)	1880 (33)
7365 (130)	9500 (167)	6930 (122)	8000 (141)
18700 (329)	22200 (390)	17200 (302)	18700 (329)
450 (8)	450 (8)	450 (8)	450 (8)
6200 (109)	7200 (126)	5480 (96)	5700 (100)

* Maximum heat rejection which occurs at rated speed, no load.

N.A. - Data is Not Available
N/A - Not Applicable to this Engine
TBD - To Be Determined

Alternator model: HCI544D

CONTROL SYSTEM	SEPARATELY EXCITED BY P.M.G.		
A.V.R.	MX321	MX341	
VOLTAGE REGULATION	± 0.5 %	± 1.0 %	With 4% ENGINE GOVERNING
SUSTAINED SHORT CIRCUIT	REFER TO SHORT CIRCUIT DECREMENT CURVES (page 7)		

CONTROL SYSTEM	SELF EXCITED		
A.V.R.	AS440		
VOLTAGE REGULATION	± 1.0 %		With 4% ENGINE GOVERNING
SUSTAINED SHORT CIRCUIT	SERIES 4 CONTROL DOES NOT SUSTAIN A SHORT CIRCUIT CURRENT		

INSULATION SYSTEM	CLASS H							
PROTECTION	IP23							
RATED POWER FACTOR	0.8							
STATOR WINDING	DOUBLE LAYER LAP							
WINDING PITCH	TWO THIRDS							
WINDING LEADS	12							
STATOR WDG. RESISTANCE	0.0049 Ohms PER PHASE AT 22°C SERIES STAR CONNECTED							
ROTOR WDG. RESISTANCE	1.77 Ohms at 22°C							
EXCITER STATOR RESISTANCE	17 Ohms at 22°C							
EXCITER ROTOR RESISTANCE	0.092 Ohms PER PHASE AT 22°C							
R.F.I. SUPPRESSION	BS EN 61000-6-2 & BS EN 61000-6-4, VDE 0875G, VDE 0875N. refer to factory for others							
WAVEFORM DISTORTION	NO LOAD < 1.5% NON-DISTORTING BALANCED LINEAR LOAD < 5.0%							
MAXIMUM OVERSPEED	2250 Rev/Min							
BEARING DRIVE END	BALL. 6220 (ISO)							
BEARING NON-DRIVE END	BALL. 6314 (ISO)							
	1 BEARING				2 BEARING			
WEIGHT COMP. GENERATOR	1393 kg				1395 kg			
WEIGHT WOUND STATOR	657 kg				657 kg			
WEIGHT WOUND ROTOR	563 kg				535 kg			
WR ² INERTIA	8.0068 kgm ²				7.7289 kgm ²			
SHIPPING WEIGHTS in a crate	1485 kg				1485 kg			
PACKING CRATE SIZE	166 x 87 x 124(cm)				166 x 87 x 124(cm)			
	50 Hz				60 Hz			
TELEPHONE INTERFERENCE	THF<2%				TIF<50			
COOLING AIR	1.035 m ³ /sec 2202 cfm				1.312 m ³ /sec 2780 cfm			
VOLTAGE SERIES STAR	380/220	400/231	415/240	440/254	416/240	440/254	460/266	480/277
VOLTAGE PARALLEL STAR	190/110	200/115	208/120	220/127	208/120	220/127	230/133	240/138
VOLTAGE SERIES DELTA	220/110	230/115	240/120	254/127	240/120	254/127	266/133	277/138
KVA BASE RATING FOR REACTANCE VALUES	500	550	500	500	575	594	625	644
X _d DIR. AXIS SYNCHRONOUS	3.02	2.99	2.53	2.25	3.52	3.25	3.13	2.96
X' _d DIR. AXIS TRANSIENT	0.16	0.15	0.13	0.12	0.17	0.16	0.15	0.14
X'' _d DIR. AXIS SUBTRANSIENT	0.11	0.11	0.09	0.08	0.12	0.11	0.11	0.10
X _q QUAD. AXIS REACTANCE	2.48	2.46	2.08	1.85	2.87	2.65	2.55	2.41
X'' _q QUAD. AXIS SUBTRANSIENT	0.27	0.28	0.23	0.20	0.31	0.29	0.28	0.26
X _L LEAKAGE REACTANCE	0.05	0.04	0.04	0.04	0.06	0.06	0.05	0.05
X ₂ NEGATIVE SEQUENCE	0.19	0.19	0.16	0.14	0.22	0.20	0.20	0.19
X ₀ ZERO SEQUENCE	0.10	0.10	0.08	0.07	0.10	0.09	0.09	0.08

WCS550 / WCS550S

Control System PLC-920 (Optional)

PowerLink PLC-920 generator controllers integrating digital, intelligent and network techniques are used as the automatic control systems for diesel generators. It can carry out functions including pre-alarm, warning & electrical trip, error, fail monitoring and controls, etc.

FUNCTION

Pre-Alarm

- Engine temperature
- Oil pressure
- Over/under voltage
- Over/under frequency
- Over/under speed

Warning & Electrical trip

- Over current
- Short circuit

Error

- Over/under speed
- Speed loss
- Battery low voltage
- Battery high voltage
- Maintenance
- Over current
- Short circuit
- Engine stop
- CAN bus
- Charge alternator

Controls

- Fuel and stop solenoid
- ECU power and stop
- Starter motor
- Automatic generator start

Preheat

- External alarm horn
- Engine cooling
- Idle mode

Fail monitoring

- Emergency stop
- Multiple engage fail
- Failed to start
- Low oil pressure
- High temperature
- Speed failure
- Voltage
- Charging fail
- Shutdown
- Warning



FEATURES

- Largest back-lit icon display in its class
- Extremely efficient power save mode
- 3 configurable analogue/digital inputs
- Configurable staged loading outputs
- 15 events log
- LCD alarm indication
- Configurable remote start input
- Power factor measurement for 3 phases
- 3 phase Load current measurement
- 3 phase alternator voltage measurement
- Configurable 4 inputs and 8 outputs
- Engine run-time scheduler
- Engine hours counter
- Automatic start control
- CAN and alternator speed sensing in one variant
- Active, Reactive, Apparent power measurement
- Fully configuration via the fascia or PC using USB communication
- Motoring Engine Speed, Coolant Temperature, Oil Pressure and Fuel Level

SPCIFICATION

- Dimensions: 140mm*113mm*43mm
- Panel cut-out: 118mm*92mm
- Protection: IP65 at front panel
- Weight: approximately 0.16kg
- Operating temperature: -30 °C to 70 °C
- DC battery supply voltage: 8 to 35V
- Max. operating current: 85mA at 12V
96mA at 24V
- CT secondary: 5A
- Flexible sensor measurement:
Full scale: 480ohm;
Accuracy: ±2%FS; Resolution: 1%

Control System function list

	MODEL	PLC-920	PLC-7420	
General accessory	AVR	●	●	
	Electronic Governing	×	×	
	Glow plug control	●	●	
	Cycle Cranking (MODBUS) Networking	●	●	
	Fault History	×	●	
Operator Interface	manual start/stop	●	●	
	Auto/remote start	●	●	
	Regular Test	●	●	
	Auto operation LED	●	●	
	Manual operation LED	●	●	
	Common Shutdown LED	●	●	
	Common warning LED	●	●	
	Fail to start LED	●	●	
	Emergency stop(local)	●	●	
	Alphanumeric screen	●	●	
Measurement and Instrumentation	Remote start input active LED	×	●	
	Alarm reset	●	●	
	Engine	Oil pressure	●	●
		Water Temperature	●	●
		Engine Speed	●	●
		Hours Run	●	●
		Number of Starts	●	●
	Alternator	Battery Voltage	●	●
		Coolant Temperature	●	●
		3Phase-L Voltage&Frequency	●	●
		3Phase Current	●	●
		Frequency	●	●
		kWh	●	●
		Apparent Power	●	●
		Active Power and Reactive Power	●	●
Power Factor		●	●	
Per PhasekW, kVAr		●	●	
Per Phase KVA	●	●		
Mains Expression	Phase Voltage	●	●	
	Output Power	×	●	
	Grid Line Voltage	×	●	
	Grid Phase Voltage	×	●	
Shutdown Protection and Indication	Grid Frequency	×	●	
	Engine	Low Fuel Level	●	●
		High Fuel Level	×	○
		Low Oil Pressure	●	●
		High Water Temperature	●	●
		Failure to Stop	●	●
	Alternator	Failure to Start	●	●
		Controllable start circles/times	×	●
		Overspeed	●	●
		Under&Over Voltage	●	●
Under&Over Frequency		●	●	
Threshold Warning/Indication	Overcurrent	●	●	
	Earth Leakage	○	○	
	Reverse Power	×	×	
	Reverse kW/r	×	×	
	Low Oil Pressure	●	●	
	Low Water Temperature	○	○	
	High Water Temperature	●	●	
	Low Water Level	●	●	
	Low/High Battery Voltage	●	●	
	Failure to Charge	●	●	
Paralleling Capability	Overcurrent	●	●	
	Overload	●	●	
	Genset Under/Over Voltage	●	●	
	Genset Under/Over Frequency	●	●	
	under/over Speed	●	●	
	High Engine Temperature	●	●	
	Earth Leakage	○	○	
	Synchroscope(Independent Bus)	×	×	
	Active and Reactive Power Control	×	×	
	Synchroscope(Shared Bus)	×	×	
Power Transfer Function	Synchronization Detector	×	×	
	Peak Lopping	×	×	
	Automatic Transfer	○	●	
	Hard Closed Transition	●	●	
	Soft Closed Transition	×	×	
	Gen/Mains Breaker	×	×	
	Gen/Mains Breaker Status Protection	×	×	
	Speed/Voltage Control	×	×	
	Power Indication	×	●	
	Fuel&Solenoid Valve Control	●	●	
Environment	Starter Control	●	●	
	Preheating	○	○	
	Mains Transfer Switch (Standard)	×	×	
	Mains Transfer Switch (Emergency)	×	×	
	Operating Temperature (-40 °C-70 °C)	●	●	
Monitoring Function	Ambient Temperature (-25 °C-45 °C)	●	●	
	Humidity <=80%	●	●	
	Grid Over/Under Voltage Control	×	●	
	Grid Over/Under Frequency Control	×	●	
	Remote Start Output(Load/No-load)	●	●	
	Optional Relay Output	●	●	
	Remote Telecom Control with All Functions	×	●	
	Engine Instrument Monitoring	●	●	
	Alternator Output Instrument Monitoring	●	●	
	Connection Point with All-around Setting For 6 Users	●	●	
3 Users Input Connection Point	●	●		
Monitoring Function	LCD Light Control of Low Light Operation Environment	●	●	
	Safe PIN Code	●	●	
	RS232/485 Interface	×	×	
	Language Selection	●	●	
	Multi-Language Function	●	●	

Control System

Digital, intelligent control system allows easier operation.

PLC-7420

PLC-7420 is an advanced control module based on micro-processor, containing all necessary functions for protection of the genset and the breaker control. It can monitor the mains supply, breaker control and automatically start the engine when the mains is abnormal. Accurately measure various operational parameters and display all values and alarms information on the LCD. In addition, the control module can automatically shut down the engine and indicate the engine failure.



FEATURES

- Microprocessor control, with high stability and credibility
- Monitoring and measuring operational parameters of the mains supply and genset
- Indicating operation status, fault conditions, all parameters and alarms
- Multiple protections; multiple parameters display, like pressure, temp. etc.
- Manual, automatic and remote work mode selectable
- Real time clock for time and date display, overall runtime display, 250 log entries
- Overall power output display
- Integral speed/frequency detecting, telling status of start, rated operation, overspeed etc.
- Communication with PC via RS485 OR RS232 interface, using MODBUS protocol

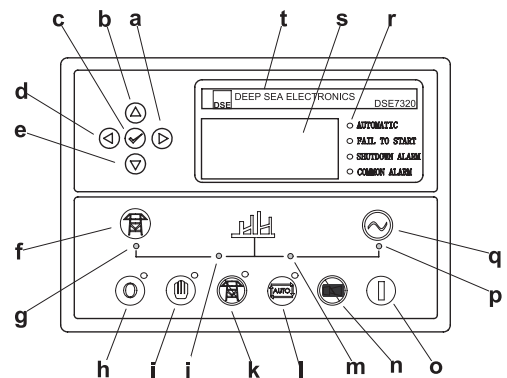

Control Panel

- a Button (next page)
- b Button (increase value / previous item)
- c Button (accept)
- d Button (previous page)
- e Button (decrease value / next item)
- f Button (transfer the load to the mains supply, when in Manual mode only)
- g Mains supply available LED
- h Stop / Reset button
- i Manual button (Manual control mode)
- j Mains supply on load LED
- k Test button (Test mode)
- l Auto button (Auto mode)
- m Genset on load LED
- n Mute/Lamp test button
- o Start button (Manual)
- p Genset available LED
- q Button (transfer the load to the genset, when in Manual mode only)
- r Alarm LED (4 alarm items)
- s LCD display
- t Control module name

Optional

Engine	Alternator	Generator Set	Fuel System	Canopy
<ul style="list-style-type: none"> • Water Jacket Preheater • Oil Preheater 	<ul style="list-style-type: none"> • Winding Temperature Measuring Instrument • Alternator Preheater • PMG • Anti-damp and anti-corrosion treatment • Anti-condensation heater 	<ul style="list-style-type: none"> • Tools with the machine 	<ul style="list-style-type: none"> • Low fuel level alarm • Automatic fuel feeding system • Fuel T-valves 	<ul style="list-style-type: none"> • Trailer
Lubricating System	Exhaust System	Cooling System	Control Panel	Voltages
<ul style="list-style-type: none"> • Oil with the machine 	<ul style="list-style-type: none"> • Protection board from hotness 	<ul style="list-style-type: none"> • Front heat protection • Coolant (-30°C) 	<ul style="list-style-type: none"> • Remote control panel • PLC-920 • PLC-7420 • ATS 	<ul style="list-style-type: none"> • 415/240V • 400/230V • 380/220V • 220/127V • 200-115V

